

I/A Series[®] Intelligent Vortex Flowmeters Foxboro Model 84S Sanitary Flowmeters with HART[®] Communication Protocol



The Foxboro Model 84S is part of a family of intelligent, high performance sanitary vortex flowmeters designed for food and pharmaceutical sanitary liquid service, and CIP (clean-in-place) systems. They transmit a 4 to 20 mA or digital multidrop, and pulse output signal, as applicable, using HART communication protocol for remote configuration, calibration, and monitoring. An On-board LCD indicator with pushbuttons is also offered for local configuration.

FEATURES

- Liquid, gas, or steam applications.
- 3A authorized per specification 28-02.
- 316L stainless steel flowtube with 25RA finish.
Also a complete line of sanitary end connections.
- Best in class accuracy:
 - $\pm 0.5\%$ of reading in liquids
 - $\pm 1.0\%$ of reading in gas and steam.
- Widest rangeability in class.
- Active Tuning[™]:
 - Real time Reynolds number (R_D) low flow correction down to R_D of 5000.
 - Compensation for piping effects.
 - Adaptive filtering and signal conditioning.
 - Tunable for specific operating conditions.
- HART communication protocol.
- *DirectSense*[™] technology with lifetime sensor warranty.
- New Pulse Output provides raw or scaled frequency, or total.
- Foxboro has a free-to-use, flow sizing program on the internet at www.FlowExpertPro.com. See next page.

SANITARY AND CIP/SIP DESIGN

The 84S Sanitary Vortex Flowmeter is 3A authorized per specification 28-02. The meter is a crevice-free design with no moving parts. The process-wetted parts are 316 ss and 316L ss and finished to 3A (25 microinch) sanitary standards. The design allows for in-line cleaning (CIP) using various combinations of cleaning solutions, air purging, or saturated steam (SIP) at temperatures to 204°C (400°F).

FlowExpertPro™

FlowExpert Pro is a program primarily used to size Foxboro flowmeters. It also ensures that the user has selected the proper flowmeter type for his application. Invensys provides this meter selection tool as a free web site to all users, without the need for registration. In addition to flowmeter selection and sizing, FlowExpertPro includes the following features:

- Incorporates a large library of the physical properties of typical process fluids.
- Displays results in tabular or graphic format.
- Allows user to save, print, or E-mail results.
- Provides reference to applicable flowmeter PSS and other related flowmeter documentation.

The program calculates minimum and maximum flow rates, rangeability, pressure loss, and R_D , using established flow equations. It also allows for material and flange selection. You are invited to visit www.FlowExpertPro.com to access this program, or contact Invensys Foxboro for further information.

WIDE VARIETY OF APPLICATIONS

This flowmeter is offered in 2 and 3 in (DN 50 and DN 80) sizes, with a large selection of common sanitary end connections. For users who do not require a 3A certification, a Class 150 RF flange end connection is also offered. It is ideally suited for the pharmaceutical, food, and dairy industries. Difficult fluids, such as some slurries, can also be measured. It can also be configured, for example, to measure the flow of liquids in a batch process without measuring the inert gas following the batch, thus providing an accurate measurement of the liquid only.

SIMPLE DESIGN FOR BEST PERFORMANCE AND RELIABILITY

This patented family of vortex flowmeters has the high accuracy and rangeability of positive displacement and turbine flowmeters without the mechanical complexity and high cost. They provide flow rate accuracy of $\pm 0.5\%$ in liquids and $\pm 1.0\%$ in gas and steam. It utilizes patented *DirectSense* technology to eliminate routine problems encountered with other vortex meters.

DirectSense technology measures pressure pulses from vortex shedding directly, without clumsy mechanical linkages. The benefits of *DirectSense* technology include:

- Provides best performance in class.
- Increased measurement sensitivity for wider rangeability.
- Greater immunity to pipe vibration.
- High reliability backed by lifetime sensor warranty.
- Replaceable sensor without recalibrating.

Because these vortex flowmeters have no moving parts, they are very durable and reliable. This simplicity of design ensures low initial cost, low operating and maintenance costs, which contribute to an overall low cost of ownership.

ActiveTuning™ (See Paragraphs below)

Reynolds Number

Patented algorithm improves accuracy performance down to an R_D of 5000.

Compensations for Piping Effects

When it is not possible to provide the recommended pipe diameters of unobstructed straight pipe upstream of the flowmeter, the 84 Series can be configured to compensate for most of the common non-ideal upstream conditions, such as elbows and reducers. Straight runs as short as 5-pipe diameters can be configured to achieve full accuracy.

Adaptive Filtering and Signal Conditioning

A patented, adaptive filtering algorithm provides real-time, dynamic frequency filters that follow the vortex shedding frequency. This results in unsurpassed low-flow measurement capability and vibration immunity. This is incorporated with a digital smoothing algorithm that conditions the raw vortex signal to virtually eliminate dropped or added pulses, further enhancing low-flow performance.

Tunable for Specific Operating Conditions

Configurable parameters for Low Flow Cut-in and damping allow tuning for specific flow conditions.

MEASUREMENT INTEGRATION

These flowmeters provide efficient integration of measurements into HART process control schemes, as follows.

HART -T and -U Versions

These versions operate by using a bidirectional digital signal superimposed on the 4 to 20 mA current signal. They are also offered with or without a pulse output. Remote communication of digital values plus status and configuration information can be achieved via HART communication protocol.

Configurators used with the HART versions are:

- The HART Communicator (users having a HART Communicator for other devices can have them upgraded with Invensys Foxboro software to accommodate these flowmeters).
- The Local Digital Indicator/Configurator with pushbuttons.

With HART, digital multidropping is permitted. This is the connection of several transmitters to a single communications line. Up to fifteen transmitters can be connected on a single twisted pair of wires or over leased telephone lines.

COMPACT, EFFICIENT, AND DURABLE DESIGN

The 84S is offered in the most common sanitary line sizes, and has the same electronics housing as the 84F (flanged) and 84W (wafer body) flowmeters. The electronics housing is of durable construction and provides environmental protection to the enclosed parts, such as the environmentally protected amplifier, local digital display/ configurator, and terminal block. The plug-in amplifier can be calibrated in place and can be replaced without interrupting the flow in the pipe.

SIMPLIFIED FLOW START-UP

No primary device calculations or mechanical calibrations are required. The flowmeter is easily installed and configured. Simply wire it to a proper power source, an I/O module, or controller, and it is ready to measure flow.

Invensys will preconfigure the flowmeter using flow data supplied by the customer. Generically configured flowmeters can be used as shipped, but for more precise application, the flowmeter should be configured to specific process usage. The configurators allow selection of the fluid type (liquid, gas, or steam) that provides general default configurations when process conditions are not available.

REMOTE MOUNTED ELECTRONICS HOUSING

The remote housing is supported by a bracket, which mounts to a surface or nominal DN 50 or 2-in pipe. This housing can be located up to a cable length of 50 ft (15.2 m) from the flowtube without loss of low level signal.

USABLE IN HAZARDOUS AREA LOCATIONS

Meet numerous Agency requirements for hazardous locations. Versions available to meet Agency flameproof and zone requirements.

“CE” COMPLIANCE

These flowmeters comply with applicable European Community Standards for immunity to EMI emissions, and pressure equipment directive (PED) 97/23/EC.

LOCAL DIGITAL INDICATOR/CONFIGURATOR

This is a full feature, 16-character digital indicator and configurator. Total flow and/or the instantaneous flow rate may be displayed in user-selected flow units. The display may be configured for either flow or total, or to toggle between them. Four pushbuttons on the indicator are used to configure the flowmeter.

OPERATING CONDITIONS (a)

Influence	Factory Calibration Conditions (b)	Operating Limits
Process Fluid	Clear Water	Liquid, Gas, and Steam
Process Temperature	70 to 85°F (20 to 30°C)	0 and +400°F (-20 and +200°C)
Ambient Temperature (Housing)	<ul style="list-style-type: none"> • 70 to 85°F (20 to 30°C) • 70 to 85°F (20 to 30°C) 	<ul style="list-style-type: none"> • 0 and +176°F (-20 and +80°C) (c) • -40 and +176°F (-40 and +80°C) (c)
Relative Humidity	50 to 90%	0 and 100%
Supply Voltage - mA Output	24 ±0.5 V dc	15.5 and 42 V dc (see Figure 2)
Output Load - mA Output	525 to 560 Ω	0 and 1350 Ω (see Figure 2)

- (a) Limit are based on nonflashing, noncavitating conditions. A minimum positive back pressure is required for proper operation to avoid these effects.
- (b) Assumes ANSI Schedule 40 process piping; flanges bored to interfacing pipe I.D.; piping and flowmeter body bores aligned to within 2% of meter bore; gaskets to be 3.18 mm (0.125 in) thick and not protruding into pipeline; a minimum of thirty pipe diameters of straight pipe upstream and five pipe diameters downstream of flowmeter; clear water is free from air or particles.
- (c) Refer to Electrical Safety Specifications table further in the document for ambient temperature limits with certain electrical certifications.

**PERFORMANCE SPECIFICATIONS
(Under Calibrated Operating Conditions unless Otherwise Stated)**

Factory Calibrated Flow Ranges

Nominal Meter Size	Nominal Mean K-Factor Pulses/ft ³ (Pulses/L) (a)	Factory-Calibrated Flow Range for Water		
		US gpm Range	L/s Range	R _D Range
2 in (DN 50)	282 (9.96)	58 to 210	3.6 to 14	100 000 to 380 000
3 in (DN 80)	78.0 (2.75)	34 to 500	2.1 to 32	38 000 to 570 000

- (a) The K-factor is the relationship between input (volumetric flow rate) and the output (pulse rate). Reference K-factor is the arithmetic mean value of K-factor over a designated flow rate range (reference conditions). The mean K-factor is derived as: Mean K-factor = (KMAX + KMIN) / 2 Where KMAX is the Maximum K-factor and KMIN is the Minimum K-factor over the calibrated flow range.

Accuracy for Liquids

Accuracy within the calibrated range is as follows (also see Figure 1):

2 in (DN 50) FLOWMETER

- Above 100 000 R_D; ±0.5%
- Between 20 000 and 100 000 R_D; ±1.0%
- Between 5 000 and 20 000 R_D; ±2.0%

3 in (DN 80) FLOWMETER

- Above 38 000 R_D; ±0.5%
- Between 20 000 and 38 000 R_D; ±1.0%
- Between 5 000 and 20 000 R_D; ±2.0%

Accuracy for Gases and Steam

Accuracy within the calibrated range is as follows: 2 in and 3 in (DN 50 and DN 80) FLOWMETERS

- Above 20 000 R_D; ±1.0%
- Between 5 000 and 20 000 R_D; ±2.0%

NOTE

To achieve the liquid, gas, and steam accuracy stated above, the flowing density and viscosity must be entered in the database configuration. Also refer to ProExpertPro.com to determine the accuracy for specific applications.

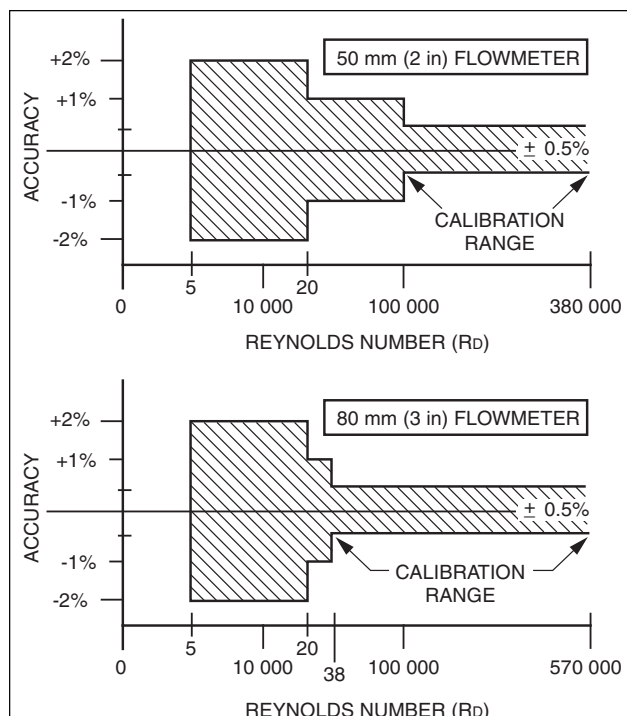

Figure 1. Flowmeter Accuracy for Liquids

PERFORMANCE SPECIFICATIONS (Cont.)

Ambient Temperature Effect (Amplifier only)

WITH PULSE OUTPUT

±0.01% of reading from
-40° to +176°F (-40° to +80°C)⁽¹⁾

WITH ANALOG OUTPUT

For 100°F (or 55°C) change in ambient
temperature within operative limits.

Zero (4 mA)

±0.1% of span maximum

Span (16 mA)

±0.1% of span maximum

WITH DIGITAL OUTPUT

±0.01% of reading from
-40° to +176°F (-40° to +80°C)

Process Temperature Effect on K-Factor

There is an effect on the reference K-factor due to a diameter change of the flowtube bore with temperature. The effect is -0.3% of flow rate for a 100°F (or 55°C) increase in temperature. This flowmeter will automatically recompute a flowing K-factor when process temperature is entered in the database fluid definition.

Supply Voltage Effect (Within Stated Limits)

WITH PULSE OUTPUT

No effect on accuracy

WITH ANALOG OUTPUT

Less than 0.005% per volt

WITH DIGITAL OUTPUT

No effect on accuracy

Relative Humidity Effect

No effect if covers and conduit seals are properly installed.

Electromagnetic Emission (EMI) and Radio Frequency Interference (RFI) Effects

The flowmeters meet the EMI and RFI requirements of EN 61326.

Position Effect (Filled Pipe Conditions)

For most applications, the flowmeter can be mounted in a pipeline which may run in any direction from the vertical (flow in upward direction) to the horizontal. Measurement of liquid and gas streams is not effected by the pipeline orientation or the flowmeter orientation in the pipeline. For steam measurement, the recommended flowmeter position is in a horizontal pipe.

(1) The 176°F (80°C) temperature may be extended to 185°F (85°C). Refer to Electrical Safety Specification table further in the document.

FUNCTIONAL SPECIFICATIONS

Direct Connectivity to Invensys Foxboro I/A Series Open Industrial System

The Model 84S can be connected directly to the I/A Series System using I/A Series fieldbus modules (FBMs). Invensys can provide the FBM applicable to your installation.

Remote Communication/Configuration

Refer to Table 1 for remote configurators/communicators used with these flowmeters.

Local Communication/Configuration

In addition to remote communications, a local digital indicator/configurator with pushbuttons is also available for local interrogation and configuration.

Password Protection

This is provided in the local display/configurator mode to assure operating security. A second level of protection is provided for configuration security.

Write Protect Jumper

A write protect jumper provides additional security by allowing the user to prevent the local indicator/configurator and remote configurator from writing to the electronics. This write protection capability meets the security requirements of ISA-584.01-1986.

Communication Format

Digital communications is provided in both the analog (4 to 20 mA) and digital modes based upon the FSK (Frequency Shift Keying) technique. See Table 1 for communication parameters.

On-Line Diagnostics

Flowmeter uses many internal diagnostic functions including hardware checks, and internal code and database validation. Error checking and diagnostic codes are also embedded in the communications protocol. These diagnostics are performed at startup and as continuous background checks.

Offline Diagnostics (Self-Test)

The configurators allow self-tests to be initiated to validate the transmitter electronics. This test uses an internally generated frequency signal.

Supply Current

- DIGITAL MODE
10 mA dc nominal
- ANALOG MODE
22 mA dc maximum
- PULSE OUTPUT
45 mA dc maximum

Supply Voltage

24 to 42 V dc, depending on electrical safety approvals and certifications. Refer to Figure 2.

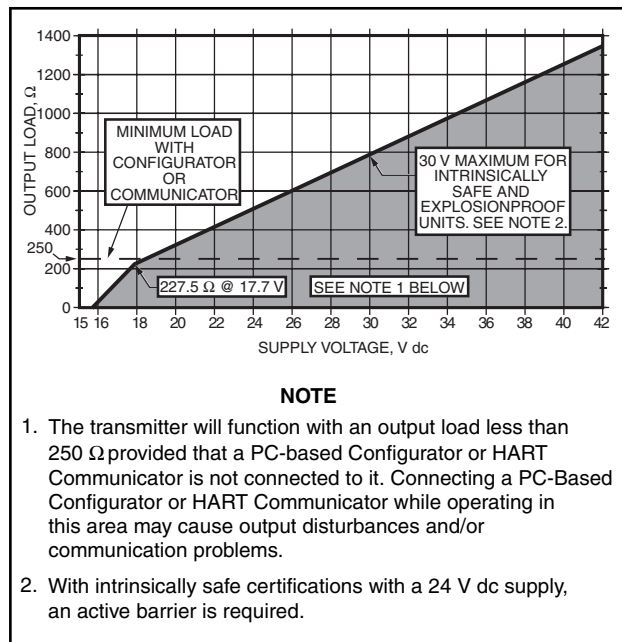

Figure 2. Supply Voltage vs Output Load for 4 to 20 mA Output

Table 1. Remote Communication Parameters

Parameter	HART	
	Analog Mode	Digital Multidrop Mode
Remote Configurator/Communicator	HART Communicator or PC-based Configurator	
Communication Rate	1200 baud	1200 baud
Communication Distance (Rated)	1800 m (6000 ft)	1800 m (6000 ft)
Flow/Total Measurement Update	5 times/s	5 times/s
Raw Pulse Measurement Update	– Vortex Shedding Frequency –	

FUNCTIONAL SPECIFICATIONS (Cont.)

Output Damping

Damping smooths the flow rate output, and optimizes the flowmeter's response time to the control system. Damping is an exponential filter with a selectable time constant; it can be set between 0 and 32 seconds. An eight second damping factor will pass 64% of the step change in this time period. Damping applies to all outputs except the Raw Pulse Output where no damping is applied to the direct vortex shedding frequency.

Response Time (Without Damping)

ANALOG MODE

0.5 second or the vortex shedding period for frequencies less than 2 Hz.

DIGITAL MODE

0.5 second or the vortex shedding period for frequencies less than 2 Hz.

PULSE OUTPUT

- Raw Pulse: Vortex shedding frequency
- Rate or Total Pulse: 0.5 s or the vortex shedding period for frequencies less than 2 Hz.

Nominal Flow Velocity Limits

These limits can be calculated using Table 2. In the table, ρ_f is the fluid density at flowing conditions in kg/m^3 or lb/ft^3 , as applicable. The specifications apply for most applications, but can deviate slightly for some combinations of density and line size. Also refer to FlowExpertPro.com.

Table 2. Nominal Flow Velocity Limits

Range Limit	Flow Velocity Limit	
	m/s	ft/s
Lower	$4.8/\sqrt{\rho_f}$	$4.0/\sqrt{\rho_f}$
Upper	$240/\sqrt{\rho_f}$	$200/\sqrt{\rho_f}$

Flowmeter Ranges

Flowmeter is shipped with flow range specified in the sales order or with a default flow range equal to the meter capacity. It can be reranged by the user keeping the same flow rate units, choosing new flowrate units from a built-in menu-selectable list, or entering custom flow rate units. Also refer to FlowExpertPro.com.

Outputs

These Flowmeters with full-featured electronics can support the following outputs:

- HART Version -T: Digital and 4 to 20 mA Output, with a pulse output
- HART Version -U: Digital and 4 to 20 mA output

ANALOG OUTPUT

Flow rate available as a 4 to 20 mA signal with the 20 mA value being set by the configured full range flow rate.

DIGITAL OUTPUT

Models 84S-T and -U

Measurements available via HART. Digital Information is superimposed on a 4 to 20 mA signal at 1200 baud (also see Table 1).

PULSE OUTPUT

The pulse output can be configured with the full-function electronics: raw pulse, rate pulse, and total pulse.

Raw Pulse

This is the vortex shedding frequency directly passed through providing an instantaneous, nondampened frequency output.

Rate Pulse

The frequency of this output is a 50% duty cycle pulse output with a frequency range of 0 to 10, 0 to 100, or 0 to 1000 Hz, proportional to zero flow to the full range flow rate/upper range value (URV).

Total Pulse

The frequency of this output is also a 50% duty cycle pulse output that is configured to provide a pulse when a determined volumetric/totalized unit has flowed through the meter.

Pulse Output Specifications

The pulse output is an externally powered 2-wire contact-closure type output. This output can be configured using any applicable configuration device to select any one of three types of pulse outputs: raw pulse, rate pulse, and scaled pulse. The following specifications apply to all three types of outputs:

- Isolated 2-Wire Contact-Closure
- Applied Voltage Limits: 17 and 30 V dc
- Maximum "ON" State Voltage Drop: 1.0 V dc
- Maximum "ON" State Current: 45 mA
- Measurement Update Rate: 5 Hz (except raw pulse which is vortex shedding frequency on a real time basis)
- Maximum "OFF" State Leakage Current:
 - 0.5 mA at 12.5 V dc
 - 2.0 mA at 24.0 V dc
 - 50 mA short circuit protected
- Reverse polarity protected.

FUNCTIONAL SPECIFICATIONS (Cont.)

Output Combinations (4 to 20 mA Outputs)

Flowmeter wired as a 2-wire device without pulse output, and as a 4-wire device with pulse output.

Reference K-Factor

The reference K-factor is a coefficient that specifies the flowmeter calibration and is expressed as pulses per unit volume, where pulses/unit volume = pulses per second divided by volume flow per second.

The reference K-factor is the arithmetic mean value of K over the factory-calibrated flow range. It is determined at the factory by actual flow calibration with water by comparison to a master flowmeter calibration, or by actual static weight. Both calibrations are traceable to NIST. The reference K-factor is entered in the flowmeter database and stamped on the data plate. Once established, this K-factor is applicable to gas, liquid, or steam applications.

Flowing K-Factor

The flowing K-factor is computed from the K-reference expressed in specified flowing units, and can be corrected for the following:

- Process Temperature
- Mating Pipe
- Upstream Disturbances

Process Temperature Correction

The flowmeter computes a corrected K-factor at the specific process temperature entered by the user.

K-Factor Bias

Provisions are made in the configuration menu to bias the flowmeter K-factor by a percent (%) value. Flowing K-factor value will be automatically recalculated when the % bias is entered.

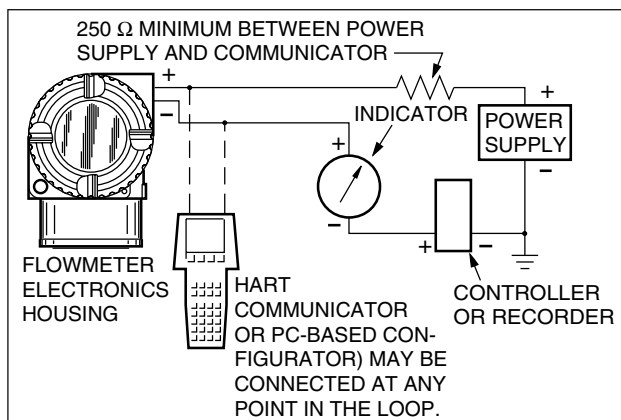

Figure 3. HART 4 to 20 mA Topology

Static Pressure Limits

MINIMUM STATIC PRESSURE

The minimum static pressure is that pressure which is sufficient to prevent flashing and meet the pressure drop requirements to attain maximum flow rate. Refer to FlowExpertPro sizing program.

MAXIMUM STATIC PRESSURE

1500 psig (103.4 bar) (10 340 kPa) or that imposed by process piping.

Approximate Pressure Loss (Pressure Drop)

The maximum pressure loss at maximum flow for any fluid is 8 psi (0.55 bar) (55 kPa). For many flow conditions, however, the actual pressure loss is much less than 8 psi (0.55 bar) (55 kPa). Use the FlowExpertPro Sizing Program to determine actual pressure loss for a given set of flow conditions.

Minimum Back Pressure (Volatile Liquids or Low Pressure Conditions)

Any condition that tends to contribute to the release of vapor from the liquid (flashing, which may also induce cavitation) shall be avoided by proper system design and operation of the flowmeter within the rated flow rate range. Location of flowmeter should consider the need for using a back-pressure valve, or for increasing inlet pressure. To avoid flashing and to ensure stable vortex generation, the minimum back pressure should be:

$$P_G = (3)(\Delta P) + (1.25)(p_v) - (p_{atm})$$

where,

P_G = Gauge pressure in psi or kPa five pipe diameters downstream of the flowmeter

ΔP = Pressure loss in psi or kPa (see "Approximate Pressure Loss" section)

p_v = Vapor pressure at line conditions in psi or kPa absolute

p_{atm} = Atmospheric pressure in psi or kPa absolute

Functional Block Diagrams

Refer to Figures 3 and 4.

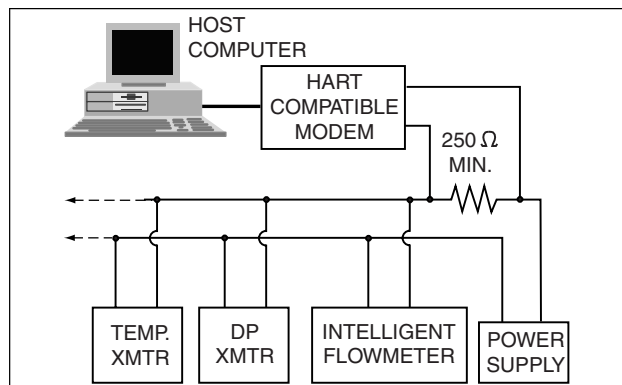

Figure 4. HART Multidrop Topology

PHYSICAL SPECIFICATIONS

Process-Wetted Parts

FLOWMETER BODY
316 ss tube
SHEDDING BAR
316L ss per ASTM 276
DETECTOR DIAPHRAGM
316L ss
END CONNECTIONS
316 ss

Detector Capsule Fill Material

Food grade silicone oil. Volume is 0.016 in³
(0.262 cm³).

Electronics Housing and Housing Covers

A two compartment housing separates the electronics from the field connections. Housing and covers are low copper, die-cast aluminum alloy with an epoxy finish. Buna-N O-ring seals are used to seal the housing covers, housing neck, and terminal block.

Mounting Configuration

The flowtube can be located in pipeline which may run in any direction from the vertical (flow in upward direction) to the horizontal. The electronics housing is mounted to a bracket, which in turn is attached to a surface in a remote location, or to a nominal DN 50 or 2 in pipe. The body and housing are electrically connected by a 15 ft (4.5 m) cable. The cable is an integral part of the flowmeter body assembly. During operation, the flow line must remain full.

Electrical Connections

Field wires enter through 1/2 NPT or M20 conduit threaded entrances on either side of the electronics housing. Wires terminate under screw terminals and washers on terminal block (see Figure 5) in the field terminal compartment. Unused entrance is plugged to insure moisture and RFI/EMI protection.

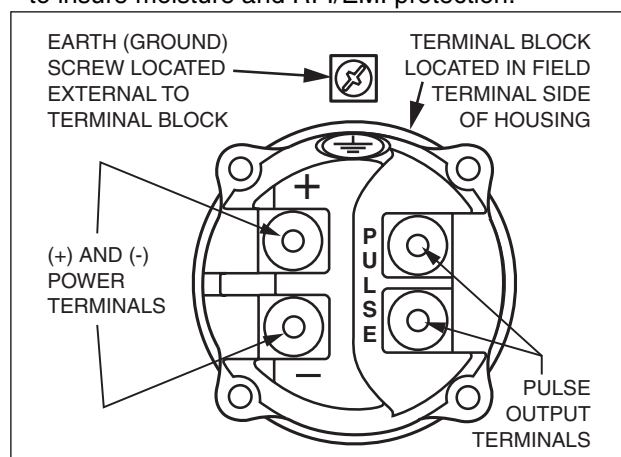

Figure 5. Terminal Block

Electronics Module

Printed wiring assemblies (PWAs) are conformally coated for moisture and dust protection.

Environmental Protection

Electronics housing is dusttight and weatherproof per IEC IP66 and provides the environmental and corrosion resistant protection of NEMA Type 4X.

Data Plate

Stainless steel data plate encircles and is secured to the lower part of the electronics housing. Includes conventional Model and operating data, including the factory calibration factor (K-factor). If additional tag data space is required, an optional Stainless Steel Customer Tag is offered.

Approximate Weight

Nominal Line Size		Flowmeter Description	Approximate Weight with	
			Connections C, M, R, T, U (a)	
mm	in		lb	kg
DN 50	2	Body and Cable	1.6	0.72
		Housing and Bracket	6.5	4.1
		Total	8.1	4.8
DN 80	3	Body and Cable	2.5	1.1
		Housing and Bracket	6.5	4.1
		Total	9	5.2

(a) Connections C, M, R, T, and U are fittings, couplings, and Tri-clamps. See Model Code.

Dimensions - Nominal

Refer to Dimensions - Nominal section for general outline data. For more details, refer to Dimensional Print DP 019-123.

PRODUCT SAFETY SPECIFICATIONS

Electrical Safety Specifications

Refer to table below.

Pressure Safety

Actual pressure-temperature limits are determined by end connections used.

Personnel and Electrical Fire Safety

This device is designed to be a minimum fire hazard by using low energy power and adequate insulation and separation of electrical circuits. The required standards of worldwide testing agencies such as FM, CSA, ATEX, IEC, and OSHA have been fulfilled.

Electrical Safety Specifications

Agency	Type of Protection	Permitted Use	Temp Class	Ta	Ambient Temperature	Electrical Safety Design Code
ATEX	Intrinsically Safe	EEx ia IIC	T4	80°C	-40 to +80°C	E (a)
ATEX	Flameproof	EEx d [ia] ia IIC	T4	80°C	-20 to +80°C	H (b)
CSA	Intrinsically Safe	Class I, II, III; Division 1; Groups A, B, C, D, E, F, and G.	T4	80°C	-40 to +80°C	C
CSA	Nonincendive	Class I, II, III; Division 2; Groups A, B, C, D, F, and G.	T4	80°C	-40 to +80°C	M
CSA	Explosionproof	Class I, II, III; Division 1; Groups A, B, C, D, E, F, and G.	T4	80°C	-20 to +80°C	D
FM	Intrinsically Safe	Class I, II, III; Division 1; Groups A, B, C, D, E, F, and G.	T4	80°C	-40 to +80°C	F
FM	Nonincendive	Class I, II, III; Division 2; Groups A, B, C, D, F, and G.	T4	80°C	-40 to +80°C	K
FM	Explosionproof	Class I, II, III; Division 1; Groups A, B, C, D, E, F, and G.	T5	80°C	-20 to +80°C	G
IECEX	Intrinsically Safe	Ex ia IIC	T4	80°C	-40 to +80°C	L (a)
IECEX	Flameproof	Ex d [ia] ia IIC	T4	80°C	-20 to +80°C	B (b)
None	No Agency Electrical Certification; (with CE mark, and PED Controls and Records).					Y
None	No Agency Certification; (no CE mark, not to be installed in European Union (EU) Countries).					Z

(a) Not available with Mounting Code R.

(b) Available with Mounting Code W only.

NOTE

1. The Model 84 has been designed to meet the electrical safety descriptions listed above. For detailed information, or status of the testing laboratory approval/certification, contact Invensys.
2. With intrinsically safe approvals and certifications with a 24 V dc supply, an active barrier is required.
3. Refer to MI 019-177 for Intrinsic Safety Connection Diagrams and Nonincendive Circuits.

OPTIONAL SELECTIONS AND ACCESSORIES

Option -N: Calibration Certificate

A calibration and pressure test sheet come standard with each flowmeter. A certified flow calibrated K-factor and pressure test certificate is available by selecting Option -N.

Options -L and -M: Foxboro Certificates of Conformance and Compliance

Two material certificates are offered. Option -L is a certificate of compliance to Foxboro specifications. The Foxboro quality system conforms to ISO 9001. Option -M is a material certificate for process wetted metal (meets DIN 50049-3.1b).

AS Code MTS: Stainless Steel Customer Tag Accessory

This tag adds 1.5 x 3.5 in (40 x 90 mm) of space for customer data that does not fit on the standard data plate. It is attached to transmitter with stainless steel wire. There can be a maximum of 10 lines of data with 40 characters and spaces per line. Tag will also show the K-factor specific to customer application (information with flowing conditions being submitted with the purchase order). Specify AS Code MTS.

MODEL CODE

Model 84S Intelligent Sanitary Vortex Flowmeter

Description

84S = Intelligent Sanitary Vortex Flowmeter

Electronics Type

- T = Intelligent Electronics, HART Communication Protocol, with Pulse Output
- U = Intelligent Electronics, HART Communication Protocol, without Pulse Output

Nominal Line Size

- 02 = 2 in (DN 50), Stainless Steel Tubing
- 03 = 3 in (DN 80), Stainless Steel Tubing

End Connection Type (Welded to Flowmeter Body) (a)

- C = 3A I-Line Fitting, Mates with Cherry Burrell 15 WI or Equivalent
- F = ANSI Class 150 RF Flange (b)
- M = Metric (DIN 11851) Coupling with External Knuckle Thread, per DIN 405, Part 1
- R = RJT Coupling per BS 1864, with External Whitworth Thread, 6 TPI
- T = 3A Tri-Clamp Type Quick-Disconnect Ferrule, Mates with Tri-Clover 14 WMP, or equivalent
- U = ISS (ISO 2853) Coupling with External Trapezoidal Thread, 8 TPI

Local Digital Indicator/Configurator

- N = No Digital Indicator/Configurator (Blind Unit)
- J = Full Function Digital Indicator/Configurator

Electronics Housing Material and Conduit Connections

- R = Remote Mounted; Aluminum Housing; 1/2 NPT Conduit Connections (two places)
- W = Remote Mounted; Aluminum Housing; M20 Conduit Connections (two places)

Electrical Safety (Also see Electrical Safety Specifications section)

- E = ATEX intrinsically Safe; EEx ia IIC; T4 (not available with mounting Code R).
- H = ATEX flameproof; for EEx d [ia] ia IIC; with Mounting Code W only.
- C = CSA intrinsically safe; Division 1; T4.
- M = CSA nonincendive; Division 2; T4
- D = CSA explosionproof; Division 1; T4.
- F = FM intrinsically safe; Division 1; T4.
- K = FM nonincendive; Division 2, T4.
- G = FM explosionproof; Division 1; T5.
- L = IECEx intrinsically safe; Ex ia IIC; T4 (not available with Mounting Code R).
- B = IECEx flameproof; EEx d [ia] ia IIC; with Mounting Code W only.
- Y = No Agency Electrical Certifications; (with CE mark, and PED Controls and Records).
- Z = No Agency Certifications; (no CE mark; Units not to be installed in European Union (EU) countries).

Optional Selections

Foxboro Certificates of Compliance/Conformance

- L = Standard Certificate of Compliance
- M = Material Certification of Process Wetted Metal (Conforms to DIN 50049-3.1.B)

Foxboro Calibration Certificate

- N = Calibration and Pressure Test Certification

Instruction Manual

- C = Detailed Instruction Manual in place of Universal MI 019-145

Example: 84S-T02CJF-LN

(a) Mating end connections, gaskets, and clamps to be supplied by the user.
(b) The ANSI Class 150 RF flange is not available if 3A certification is required.

SUGGESTED RFQ SPECIFICATIONS FOR VORTEX FLOWMETER

The manufacturer shall provide field-mounted sanitary vortex flowmeters (3A authorized) featuring digital signal processing techniques capable of accurately measuring liquid, gas, or steam flows. The specifications for these meters are as follows:

Communication Protocol:	HART
Outputs:	Analog (4 to 20 mA) and digital, with or without pulse output.
Remote Communications:	Direct digital with HART Multidrop.
Configuration:	Can be configured from the LCD indicator, HART communicator, or PC-based configurator.
Accuracy:	0.5% of reading in liquids, 1.0% of reading in gas and steam.
Internal Flow Totalizer:	Standard.
Sensor:	Replaceable without meter recalibration required.
EMC Compatibility:	Complies with International and European Union 61326 standards.
Voltage Supply:	2-wire 24 V dc loop powered.
Electronics Housing:	Remote mounted housing (with epoxy finish); integral 4.5 m (15 ft) cable from flowtube to housing.
Electronics:	Enclosed in a NEMA 4X (IEC IP66) housing sealed with O-rings for protection against moisture or other contaminants, optional integral LCD indicator with on-board configuration pushbuttons.
Body and Shedder Bar Materials:	316 or 304 stainless steel, Hastelloy C.
Electrical Classification:	Must be suitable for Class 1 Division 1, Class 1 Division 2, ATEX zone 1, or ATEX zone 2 hazardous locations, and conform to all applicable European Union directives.
Model Code:	Foxboro 84S Series Vortex Flowmeter, or equivalent.

DIMENSIONS—NOMINAL

**mm
in**

84S FLOWMETER WITH REMOTE MOUNTED ELECTRONICS HOUSING

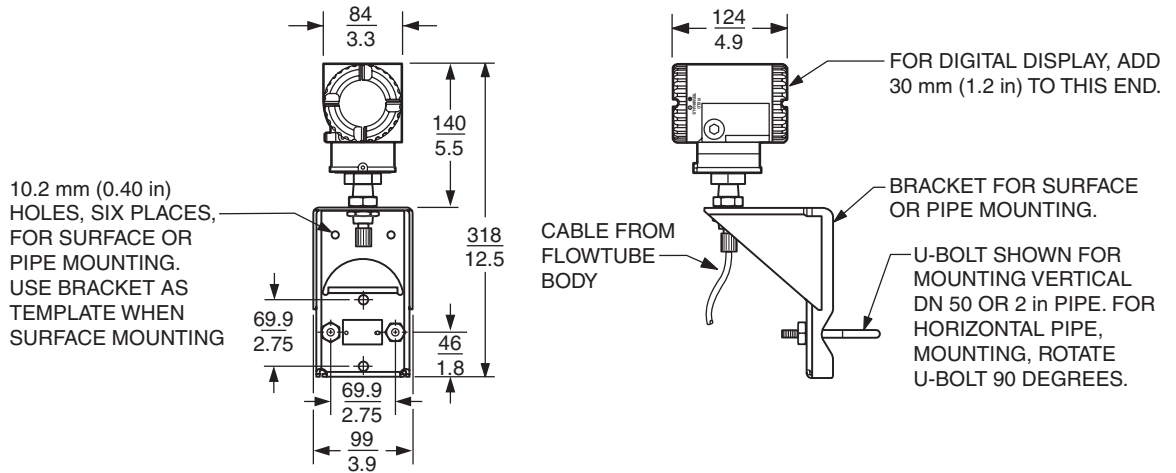

FLOWTUBE BODY

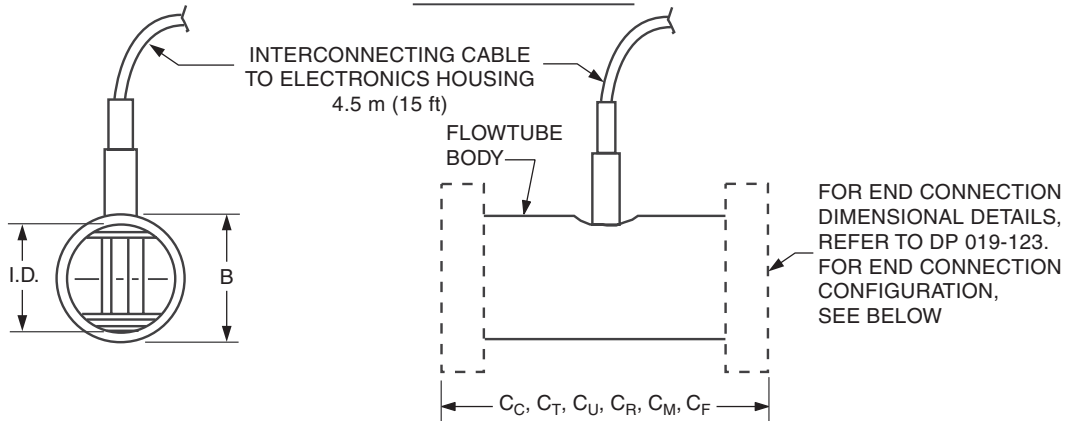

Line Size		I.D.	B	Face-to-Face Dimensions					
mm	in			C_C	C_T	C_U	C_R	C_M	C_F
DN 50	2	$\frac{47.50}{1.870}$	$\frac{50.8}{2.00}$	$\frac{155}{6.1}$	$\frac{127}{5.0}$	$\frac{145}{5.7}$	$\frac{160}{6.3}$	$\frac{173}{6.8}$	$\frac{254}{10.0}$
DN 80	3	$\frac{72.90}{2.870}$	$\frac{76.2}{3.00}$	$\frac{213}{8.4}$	$\frac{178}{7.0}$	$\frac{196}{7.7}$	$\frac{211}{8.3}$	$\frac{334}{9.2}$	$\frac{251}{9.9}$

END CONNECTION CONFIGURATIONS

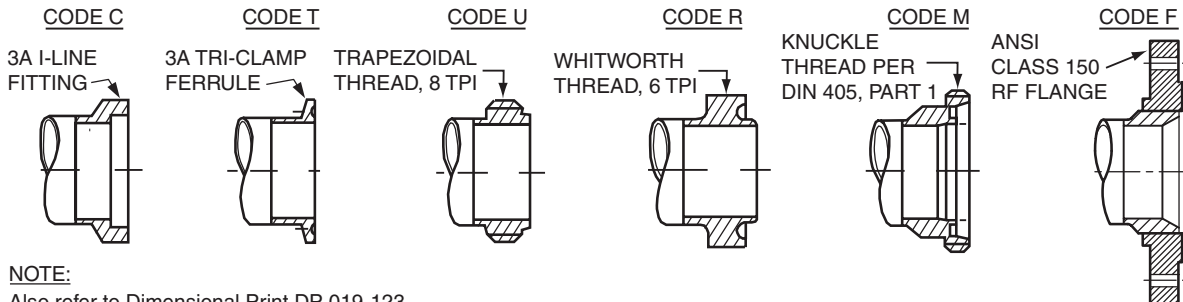

NOTE:
Also refer to Dimensional Print DP 019-123.

ORDERING INSTRUCTIONS

1. Model Number.
2. Flow Data:
 - a. Maximum, minimum, and normal flow rate.
 - b. Fluid composition and viscosity at operating temperatures.
 - c. Fluid density or relative density (specific gravity).
 - d. Maximum, minimum, and normal operating temperatures.
 - e. Maximum, minimum, and normal operating pressures.
 - f. Mating pipe schedule.
 - g. Type and location (distance) of upstream disturbances.
3. Calibration Information (analog output only); maximum flow rate at 20 mA output.
4. Electrical Classification.
5. Optional Selections and Accessories;
Select from Model Code or "Optional Selections and Accessories" section
6. Customer Tag Data.

PATENT NOTICE

This product and its components are protected by one or more of the following U.S. Patents.

3,948,098; 4,085,614; 4,520,678; 5,003,827; 5,209,125 and others pending. Corresponding patents have been issued or are pending in other countries.

OTHER M&I PRODUCTS

Invensys Foxboro provides a broad range of measurement and instrument products, including solutions for pressure, flow, analytical, positioners, temperature, controlling and recording. For a listing of these offerings, visit the Invensys Foxboro web site at:

www.foxboro.com/instrumentation

33 Commercial Street
Foxboro, MA 02035-2099
United States of America
www.foxboro.com
Inside U.S.: 1-866-746-6477
Outside U.S.: 1-508-549-2424
or contact your local Foxboro
representative.
Facsimile: 1-508-549-4999

Invensys, Foxboro, *DirectSense*, FlowExpertPro, and I/A Series are trademarks of Invensys plc, its subsidiaries, and affiliates.
All other brand names may be trademarks of their respective companies.

Copyright 2006 Invensys Systems, Inc.
All rights reserved

MB 010

Printed in U.S.A.

1006